



How to Size a Pole

Design Criteria, Wind Speeds, & EPA

10/9/25



Agenda

- 1) [Intro to Sizing a Pole](#)
- 2) [Building Codes and Wind Speeds](#)
 - 2.1 Wind Maps
- 3) [Static and Dynamic Loads](#)
- 4) [How to Size a Pole - Process](#)
- 5) [Resources and Links](#)



1

Intro to Sizing a Pole

WHAT DOES IT MEAN TO “SIZE” A POLE?

Pole shafts come in several **diameters** and **wall thicknesses** that vary based on the **shape** and **material** of the pole.

Ex. Square Straight Steel

SSS												
Series	Nominal fixture mounting height	Nominal shaft base size/wall thickness ¹										
SSS	10'-39' (for 1/2 ft increments, add -6 to the pole height. Ex: 20-6 equals 20ft 6in.)	<table border="1"> <tr> <td>4C</td> <td>4" 11g (0.120")</td> </tr> <tr> <td>4G</td> <td>4" 7g (0.179")</td> </tr> <tr> <td>5C</td> <td>5" 11g (0.120")</td> </tr> <tr> <td>5G</td> <td>5" 7g (0.179")</td> </tr> <tr> <td>6G</td> <td>6" 7g (0.179")</td> </tr> </table>	4C	4" 11g (0.120")	4G	4" 7g (0.179")	5C	5" 11g (0.120")	5G	5" 7g (0.179")	6G	6" 7g (0.179")
4C	4" 11g (0.120")											
4G	4" 7g (0.179")											
5C	5" 11g (0.120")											
5G	5" 7g (0.179")											
6G	6" 7g (0.179")											

Square Straight Aluminum

SSA														
Series	Nominal fixture mounting height	Nominal shaft base size/wall thickness ¹												
SSA	8'-35' (for 1/2 ft increments, add -6 to the pole height. Ex: 20-6 equals 20ft 6in.)	<table border="1"> <tr> <td>4C</td> <td>4" (0.125")</td> </tr> <tr> <td>4G</td> <td>4" (0.188")</td> </tr> <tr> <td>5G</td> <td>5" (0.188")</td> </tr> <tr> <td>6G</td> <td>6" (0.188")</td> </tr> <tr> <td>6J</td> <td>6" (0.250")</td> </tr> <tr> <td>7J</td> <td>7" (0.250")</td> </tr> </table>	4C	4" (0.125")	4G	4" (0.188")	5G	5" (0.188")	6G	6" (0.188")	6J	6" (0.250")	7J	7" (0.250")
4C	4" (0.125")													
4G	4" (0.188")													
5G	5" (0.188")													
6G	6" (0.188")													
6J	6" (0.250")													
7J	7" (0.250")													

Diameter Wall Thickness

Selecting the correct combination of shaft diameter and wall thickness to ensure structural stability of the pole is what we call “sizing a pole”. This process always requires careful consideration.



WHY DO WE NEEDS TO “SIZE” POLES?

To ensure that the pole will not be overstressed from the **loading forces** applied, causing a safety hazard if the pole were to fail and fall due to excessive loading.



WHAT IS REQUIRED TO “SIZE” A POLE?

Selecting the correct pole size can be a confusing process. To help remove the veil, we are going to go over the information required to correctly and accurately size the pole for a specific application, how to gather the information, and examples.

Required information for sizing a pole:

1. [Design Criteria AKA Building Code](#) of your job site
2. [The Anticipated Maximum Wind Speed](#) of your job site based on #1
3. [Static Loading Forces](#): Non-variable loads of mounted items (weight)
4. [Dynamic Loading Forces](#): Variable loads of mounted items (EPA)
5. [Pole Height](#)





2

Design Criteria and Wind Speeds

1) DESIGN CRITERIA / BUILDING CODE

Pole Design Criteria AKA **Building Code**, is a set of standards and calculations developed using a variety of engineering design experience, testing, and wind maps. Each criteria uses a specific **wind map** that is critical in finding the second piece of required information.

Design criteria is created by governing bodies such as the American Association of State Highway and Transportation Officials (AASHTO), International Building Code (IBC), and Florida Building Code (FBC).

Design Criteria can be found in the project's spec. document

It is can be selected by:

- Local and state jurisdictions
- Contractors
- Structural Engineers
- Job Specification Writers

2.4 POLES

Provide poles designed for wind loading of 161 km/hr determined in accordance with AASHTO LTS while supporting luminaires and all other appurtenances indicated. The effective projected areas of luminaires and appurtenances used in calculations shall be specific for the actual products provided on each pole. Poles shall be anchor-base type designed for use with underground supply conductors. Poles shall have oval-shaped handhole having a minimum clear opening of 65 by 130 mm. Handhole cover shall be secured by stainless steel captive screws. Metal poles shall

WHAT IS A WIND MAP?

Wind maps are important because they provide the second requirement to size a pole, the **anticipated maximum wind speed** that is specific to the job site's location. In the USA, wind maps are produced by the American Society of Civil Engineers (ASCE). As new wind maps are developed, the wind speed calculation methods become more stringent.

There are 3 main wind maps used for poles. There are other, newer wind maps but, they are not often used for pole sizing and design.

- 1. ASCE 7-93:** Made in 1993, Wind speeds on this map are formulated using the least stringent method of measurement.
- 2. ASCE 7-05:** Made in 2005, Is now the most commonly used wind speed map for poles.
- 3. ASCE 7-10:** Made in 2010, Becoming more common in high-risk, coastal areas and its method of wind speed calculation is the most stringent of the 3 listed here.

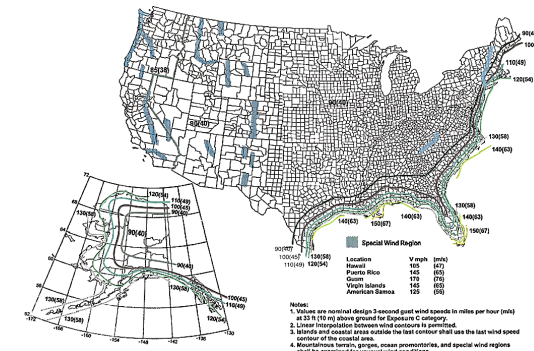
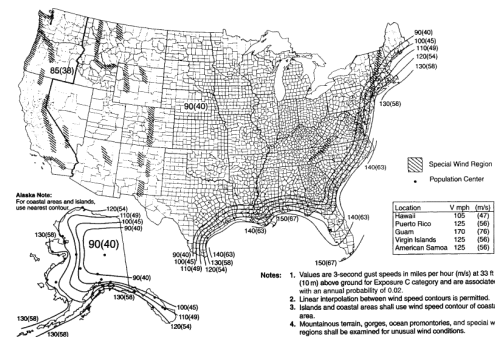
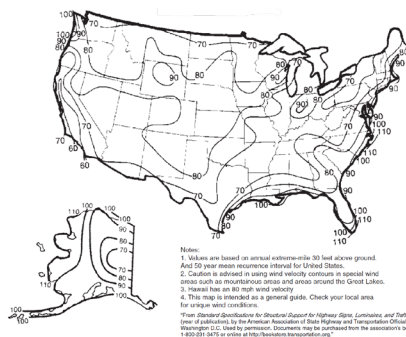

2) ANTICIPATED MAXIMUM WIND SPEEDS

Design Criteria AKA **Building Codes** are the first requirement because you **must** know this to determine the correct wind map to find the second requirement, the **anticipated maximum wind speed** for your job site's location.

As new criteria and more stringent wind maps are developed, the anticipated maximum wind speeds increase.



Anticipated maximum wind speed is required to know the pole's limits for the 3rd and 4th requirements - static loads (weight) and dynamic loads (EPA). These limits decrease as the wind speed increases.

Once the design criteria is determined, you can identify the specific wind map used to develop the criteria. This specific wind map should be used to find the second requirement – Maximum anticipated wind speed.

PUTTING DESIGN CRITERIA & WIND MAPS TOGETHER

Based on the **Design Criteria** AKA **Building Code** chosen for a job, the **anticipated maximum wind speed** for your location can change drastically. The higher the wind speed, the larger the pole size must be to prevent overstressing.

Ex. Miami, FL

Commercial Criteria

ASCE 7-93

110 mph

FBC 2004

ASCE 7-05

145 mph

FBC 2023

ASCE 7-22

180 mph

Ex. Chicago, IL

Commercial Criteria

ASCE 7-93

80 mph

AASHTO 2013

ASCE 7-05

90 mph

AASHTO 2015

ASCE 7-10

120 mph

Ex. Oakland, CA

Commercial Criteria

ASCE 7-93

70 mph

AASHTO 2013

ASCE 7-05

85 mph

AASHTO 2015

ASCE 7-10

110 mph

The building code can be the determining factor on whether your pole sizing, with it's mounted items, passes or fails for your location.





2.1

Wind Maps & Corresponding Building Codes

AASHTO 1993 & 1994 DESIGN CRITERIA (LTS-3)

Uses wind map ASCE 7-93:

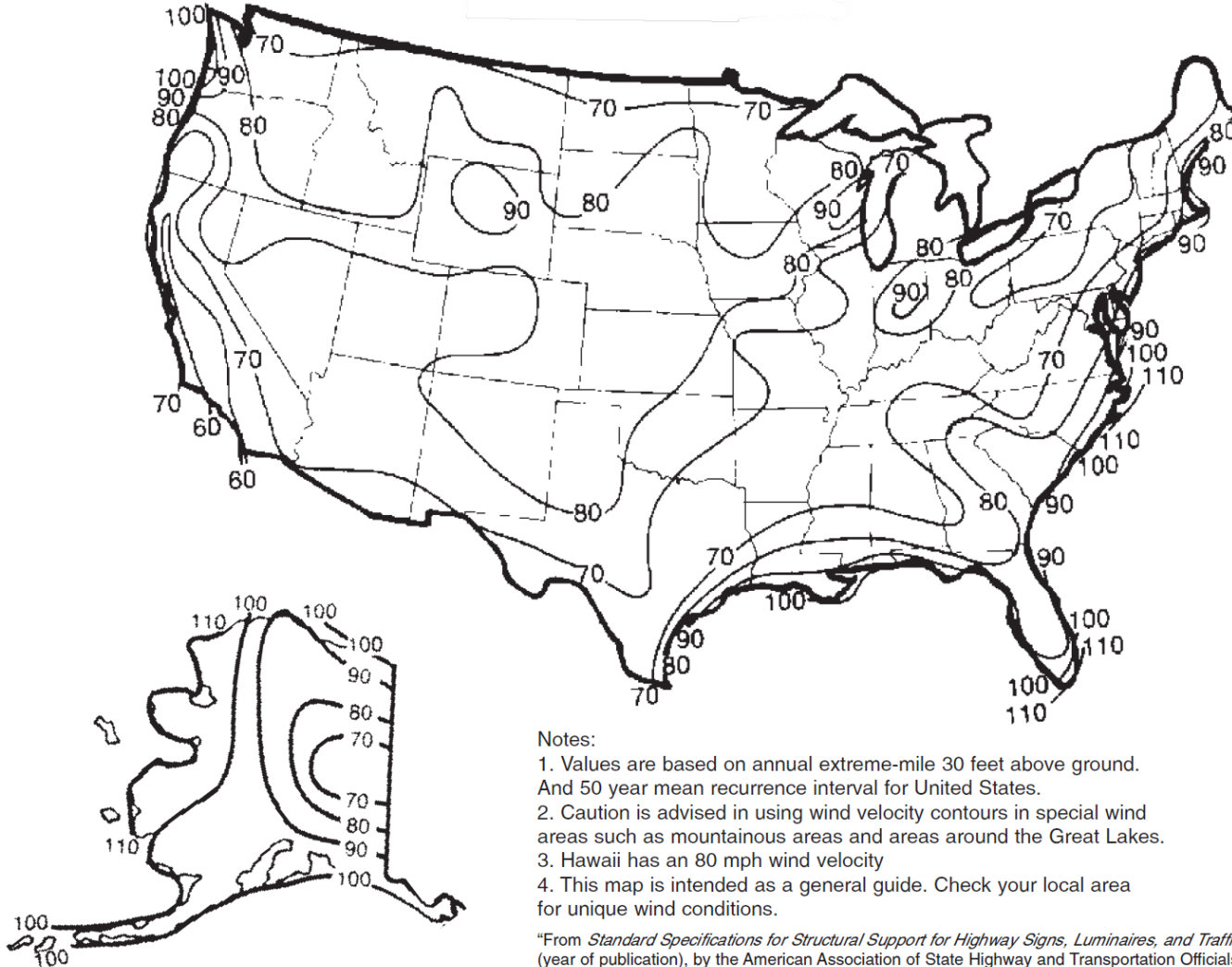

Notes:

1. Values are based on annual extreme-mile 30 feet above ground. And 50 year mean recurrence interval for United States.
2. Caution is advised in using wind velocity contours in special wind areas such as mountainous areas and areas around the Great Lakes.
3. Hawaii has an 80 mph wind velocity
4. This map is intended as a general guide. Check your local area for unique wind conditions.

"From *Standard Specifications for Structural Support for Highway Signs, Luminaires, and Traffic Signals*, (year of publication), by the American Association of State Highway and Transportation Officials, Washington D.C. Used by permission. Documents may be purchased from the association's bookstore at 1-800-231-3475 or online at <http://bookstore.transportation.org>."

It uses the Fastest-mile wind speed calculation. This is the average speed during the time required for the wind passage over an anemometer of a volume of air with a horizontal length of one mile.

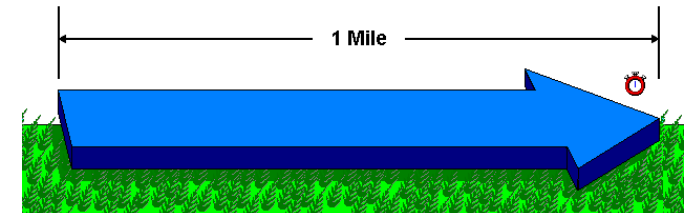

Fastest Mile Wind
With $(1.3)^2$ or 1.69 Gust Factor

This measurement of wind speed is the least stringent used for poles.



AASHTO 2001 DESIGN CRITERIA (LTS-4)

Uses wind map ASCE 7-95:

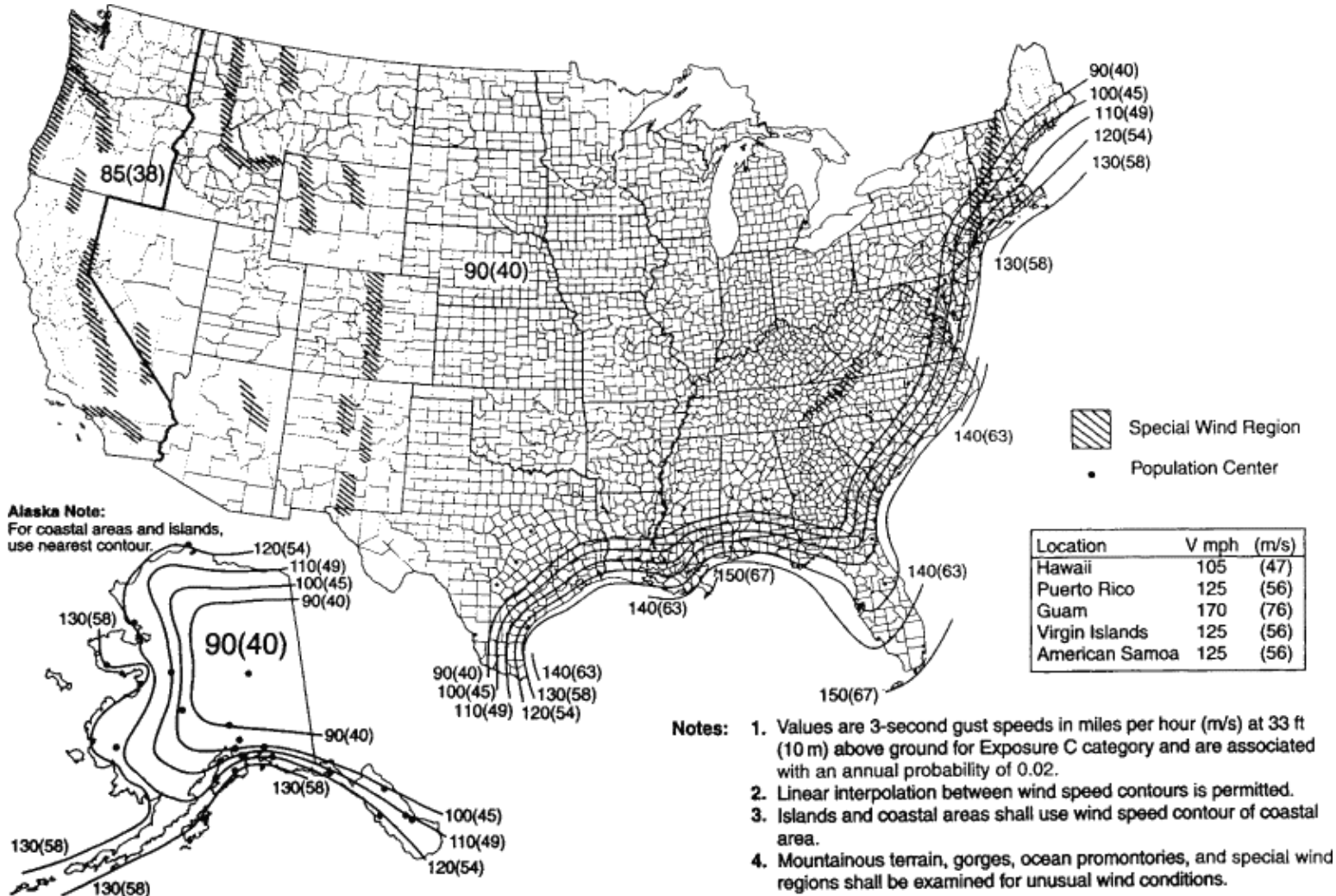

It uses the 3-second gust wind speed calculation. This is the average speed of the wind during a peak 3-second interval. This method of calculation produces higher wind speed than ASCE7-93. To offset this, the gust effect factor was lowered to 1.14.

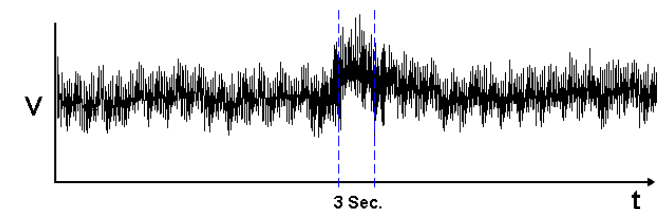

3-Second Gust Wind
With 1.14 Gust Factor

AASHTO 2009 DESIGN CRITERIA (LTS-5)

Uses wind map ASCE 7-05:

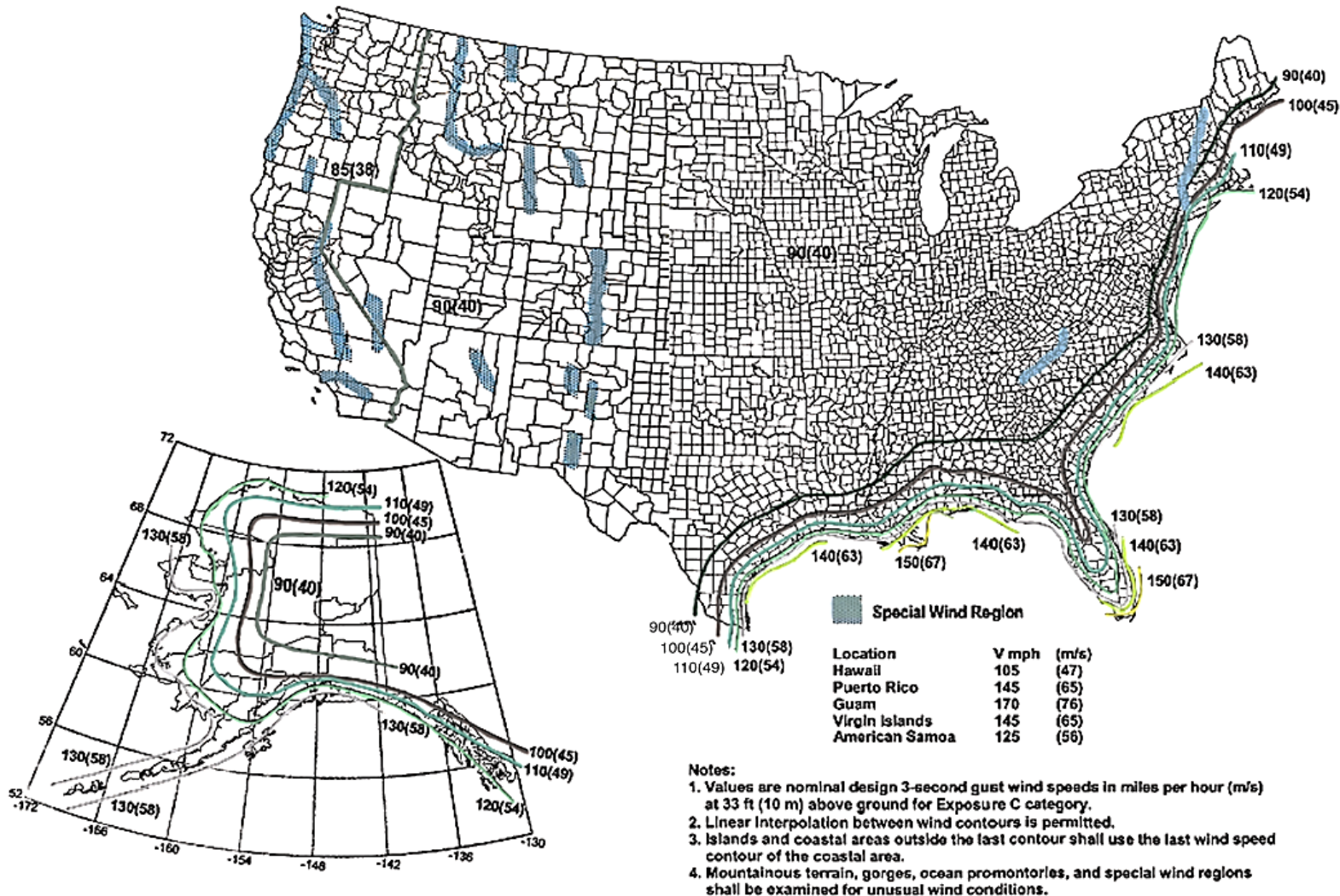

This also uses the 3-second gust wind speed calculation but, in miles per hour (m/s) at 33ft (10m) above ground for Exposure C Category.

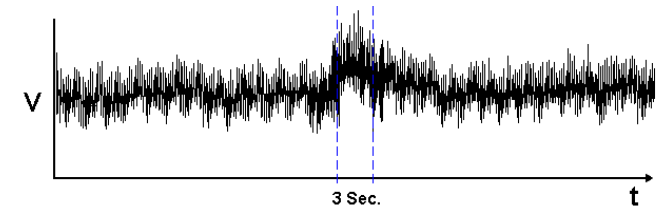

3-Second Gust Wind
With 1.14 Gust Factor

AASHTO 2013 DESIGN CRITERIA (LTS-6)

Uses wind map ASCE 7-05:

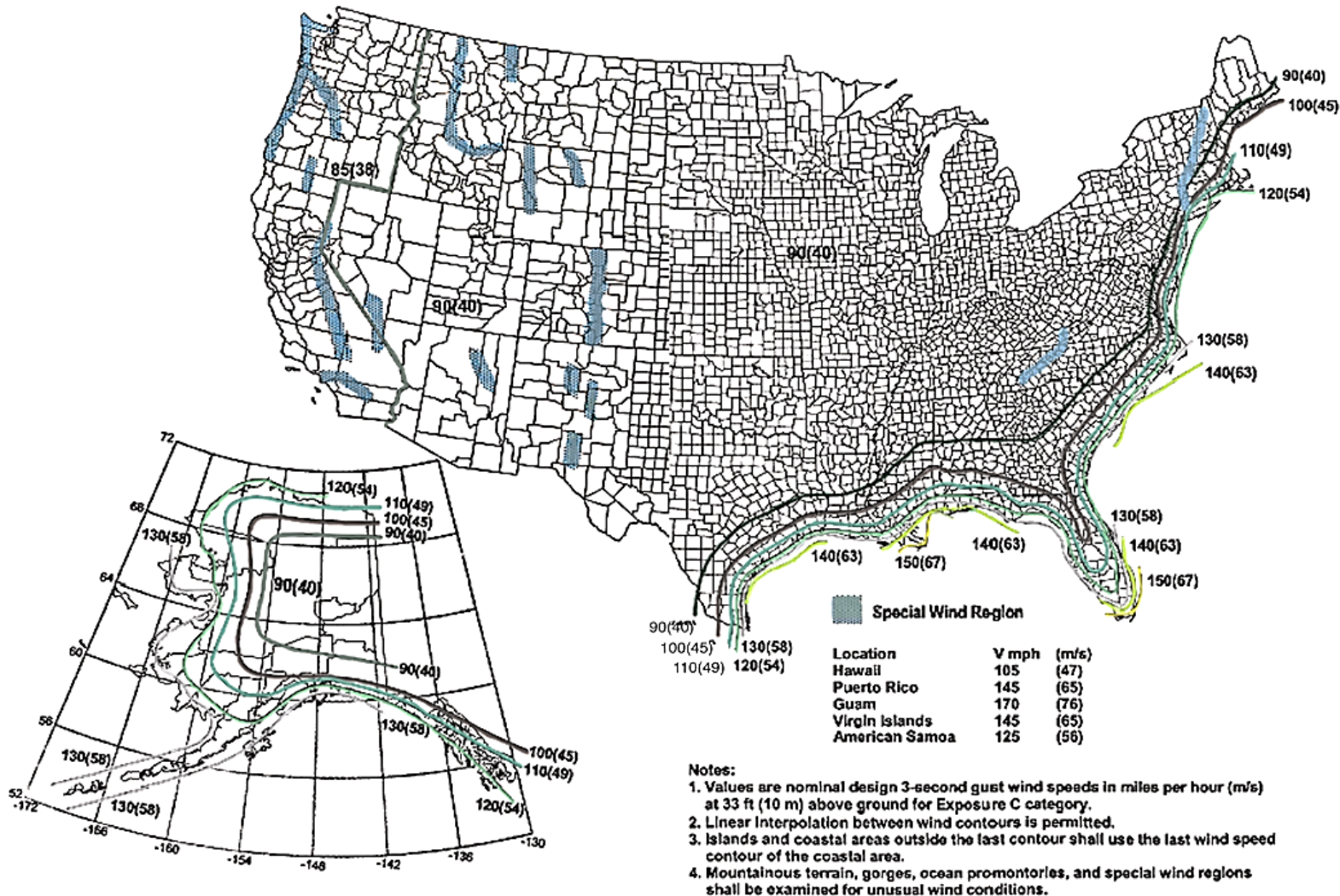

This also uses the 3-second gust wind speed calculation at 33' above ground and accounts for fatigue of poles on high mast poles (55' +).

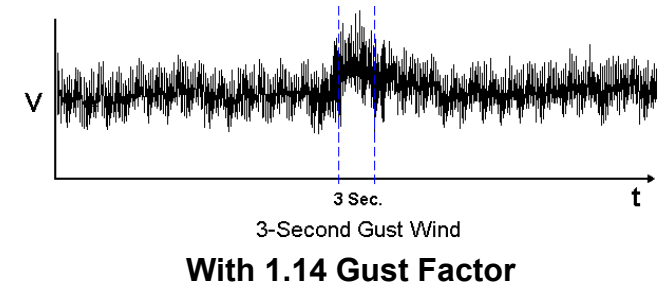

This measurement of wind speed is the most common used for poles.



AASHTO 2015 (LRFD), IBC 2012 & 2015 DESIGN CRITERIA

Use wind map ASCE 7-10:

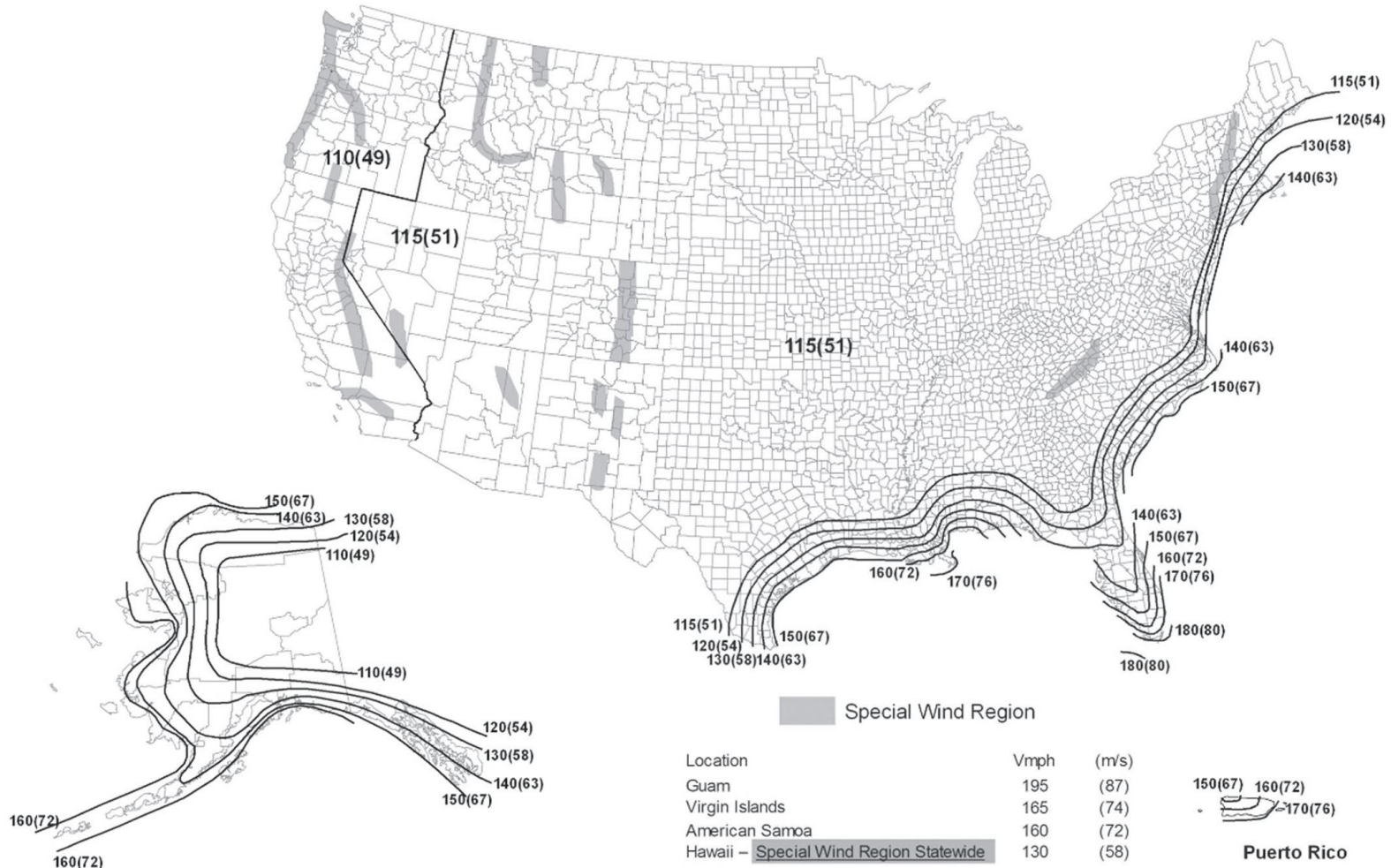

Notes:
 1. Values are nominal design 3-second gust wind speeds in miles per hour (m/s) at 33 ft (10m) above ground for Exposure C category.
 2. Linear interpolation between contours is permitted.
 3. Islands and coastal areas outside the last contour shall use the last wind speed contour of the coastal area.
 4. Mountainous terrain, gorges, ocean promontories, and special wind regions shall be examined for unusual wind conditions.
 5. Wind speeds correspond to approximately a 7% probability of exceedance in 50 years (Annual Exceedance Probability = 0.00143, MRI = 700 Years).

This uses the Ultimate 3-second gust wind speed calculation. The wind speed for your location will vary greatly and is defined by the Risk category for your location.

This measurement is not commonly used for poles in the United States. However, it is used for International applications.

A detailed wind map can be found online [here](#).



IBC 2018 & 2021 DESIGN CRITERIA

Uses wind map ASCE 7-16:

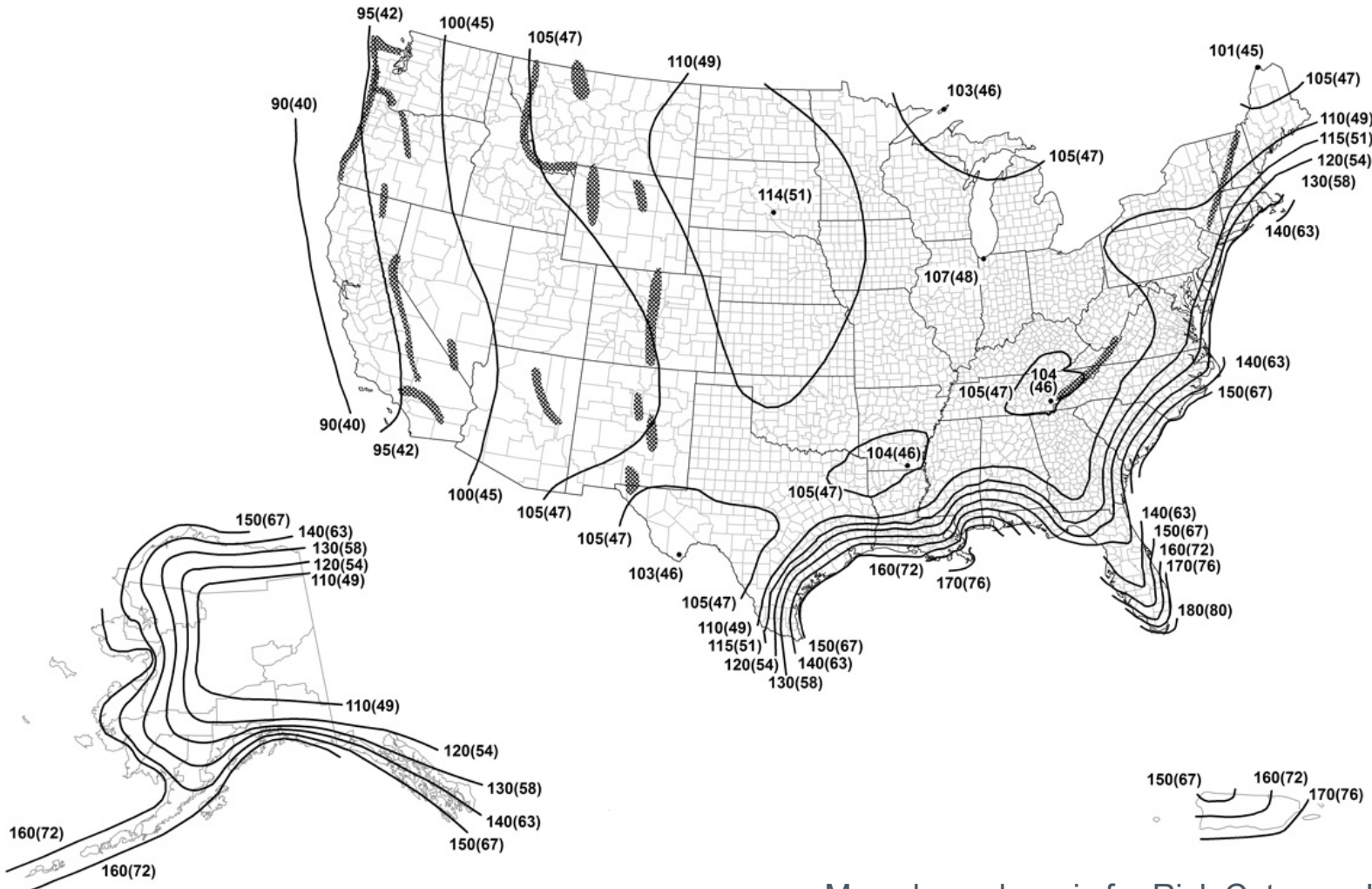

Map shown here is for Risk Category II.

This uses the Ultimate 3-second gust wind speed calculation. The wind speed for your location will vary greatly and is defined by the Risk category for your location.

This measurement is not commonly used for poles in the United States. However, it is used for International applications.

A detailed wind map can be found online [here](#).



FBC 2023 DESIGN CRITERIA

Uses wind map ASCE 7-22:

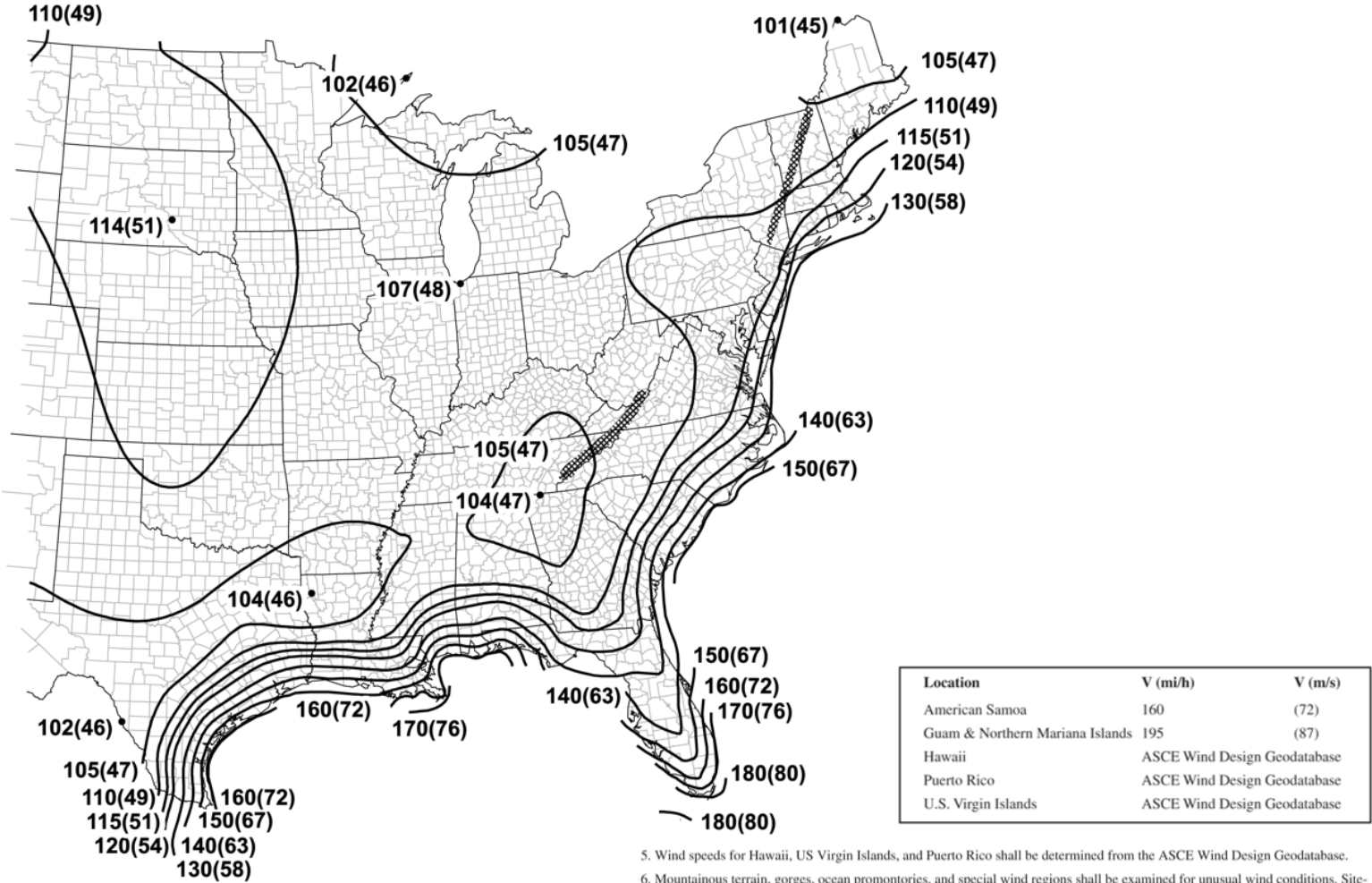

This uses the Ultimate 3-second gust wind speed calculation. Speeds correlate to specific return periods (ie. 700-year MRI for general use) and risk categories which is determined by the potential impact on human safety if the structure fails.

This measurement is almost exclusively used for poles located in Florida.

A detailed wind map can be found online [here](#).

 Special Wind Region

5. Wind speeds for Hawaii, US Virgin Islands, and Puerto Rico shall be determined from the ASCE Wind Design Geodatabase.
 6. Mountainous terrain, gorges, ocean promontories, and special wind regions shall be examined for unusual wind conditions. Site-specific values for selected special wind regions shall be permitted to be determined using the ASCE Wind Design Geodatabase.
 7. Wind speeds correspond to approximately a 7% probability of exceedance in 50 years (Annual Exceedance Probability = 0.00143, MRI = 700 years).
 8. The ASCE Wind Design Geodatabase can be accessed at the ASCE 7 Hazard Tool (<https://asce7hazardtool.online>) or approved equivalent.



SUMMARY – DESIGN CRITERIA, WIND MAPS & CALCULATION METHODS

Least Stringent
Measurement

Most Stringent
Measurement



Fastest Mile

- $(1.3)^2$ gust factor
- Wind Maps used: ASCE 7-93
- Design criteria's that use this calculation:
 - Commercial Criteria
 - AASHTO 1994

3-second gust

- 1.14 gust factor
- Wind Maps used: ASCE 7-95 and ASCE 7-05
- Design criteria's that use this calculation:
 - AASHTO 2001, 2009 & 2013
 - FBC 2004 & 2007
 - IBC 2000, 2006 & 2009

Ultimate 3-second gust

- 1.14 gust factor
- Wind Maps used: ASCE 7-10
- Design criteria's that use this calculation:
 - AASHTO 2015
 - IBC 2012 & 2015
 - FBC 2010 & 2014

3

Static and Dynamic Loads

3 & 4) STATIC VS. DYNAMIC LOADS

Static loads: Non-variable loads applied to an object or assembly.

In the context of poles, it is the dead weight of luminaires and other items mounted to the pole. An exception of an intermittent change and increase in this load, would be due to icing in cold climates. The heavier the item, the greater the load, the larger the pole will need to be.

Dynamic loads: Variable loads that change over time.

In the context of poles, dynamic loads are created by the pressure of wind based on its velocity against the surface area of the pole, its luminaire and other mounted items. This surface area is expressed as Effective Projected Area (EPA).

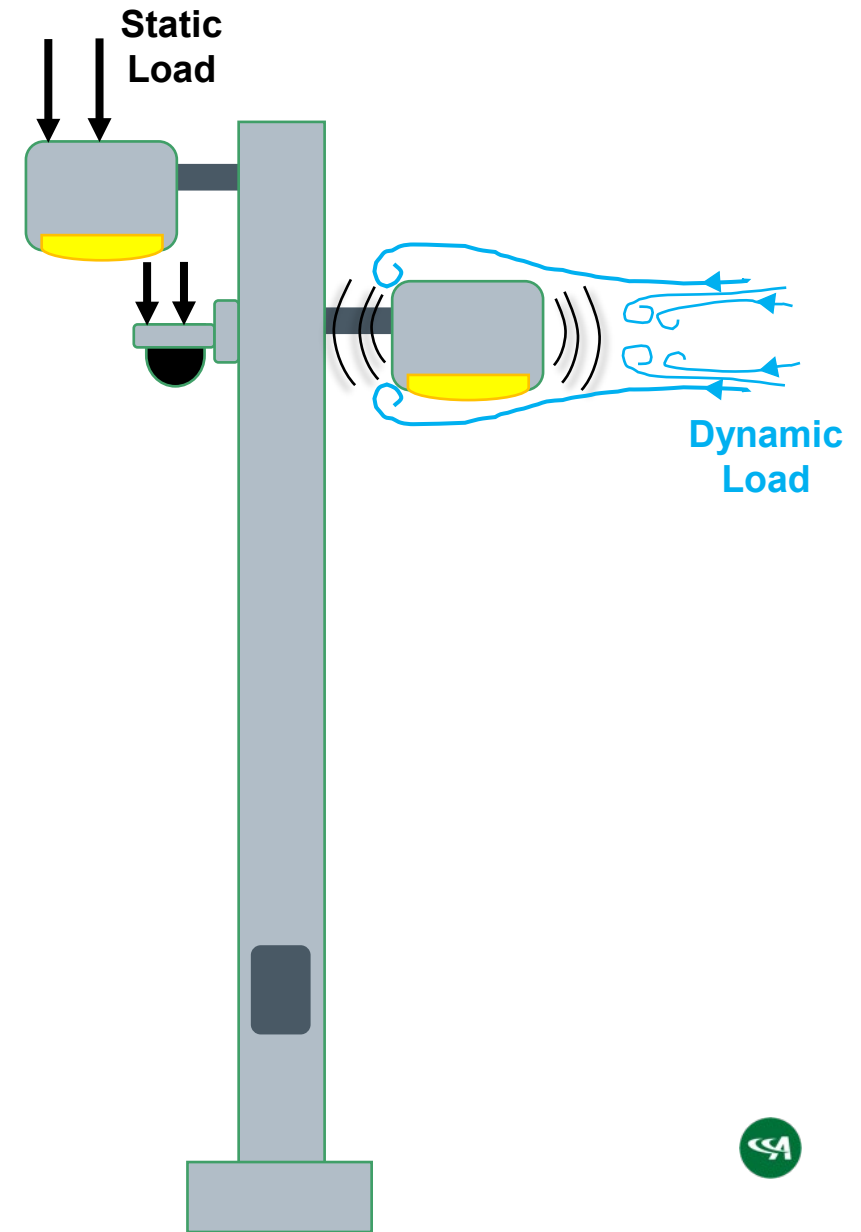

EFFECTIVE PROJECTED AREA (EPA)

Effective Projected Area: A measurement used by the lighting industry to determine the wind-induced, dynamic load any mounted item will apply to a pole or bracket at a given wind velocity.

The EPA of a luminaire is calculated by multiplying the luminaire's Projected Area (A) by its Drag Coefficient (C_d).

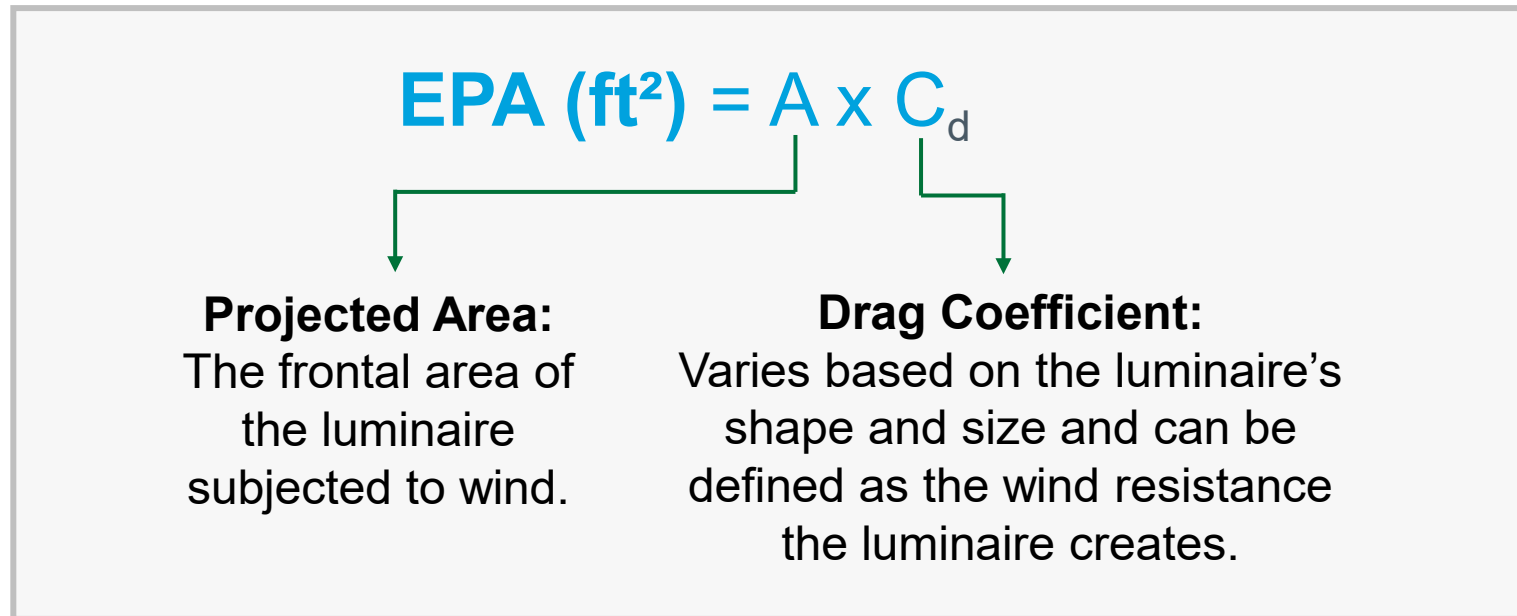

EPA Cont.

SO....The greater the Projected Area and Drag Coefficient, the higher, or worse the EPA measurement will be for the mounted item, increasing the dynamic load on the pole.

Ex. A large shoebox or square luminaire will have a higher EPA and present more resistance to the wind than a wing shape.

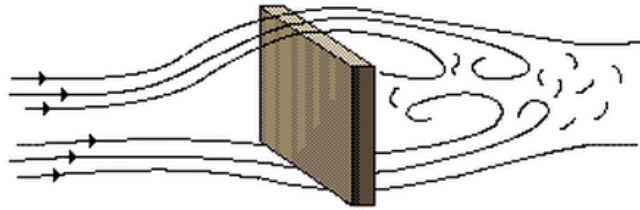

Square

Flat edged objects like boxes experience the highest amount of drag

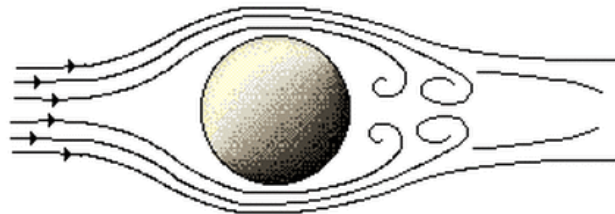

Sphere

Spherical objects like baseballs experience a medium amount of drag

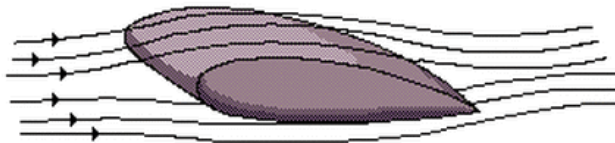

Airfoil (wing)

The shape of an airplane wing experiences the least amount of drag

COMBINING STATIC & DYNAMIC LOADS W/ DESIGN CRITERIA & WIND SPEEDS

As mentioned earlier, each specific **Design Criteria** AKA **Building Codes** has its own set of standards, calculations, wind map, and corresponding anticipated maximum wind speed for a given location.

Engineers combine these standards, calculations and anticipated maximum wind speeds with factors like pole height, design specifications, and shape to determine **maximum static load (weight)** and **maximum dynamic load (EPA)** the pole can handle until it's overstressed and fails.

These maximums decrease with:

- Increased pole height
- Increased wind speed
- A more stringent Design Criteria



5) POLE HEIGHT

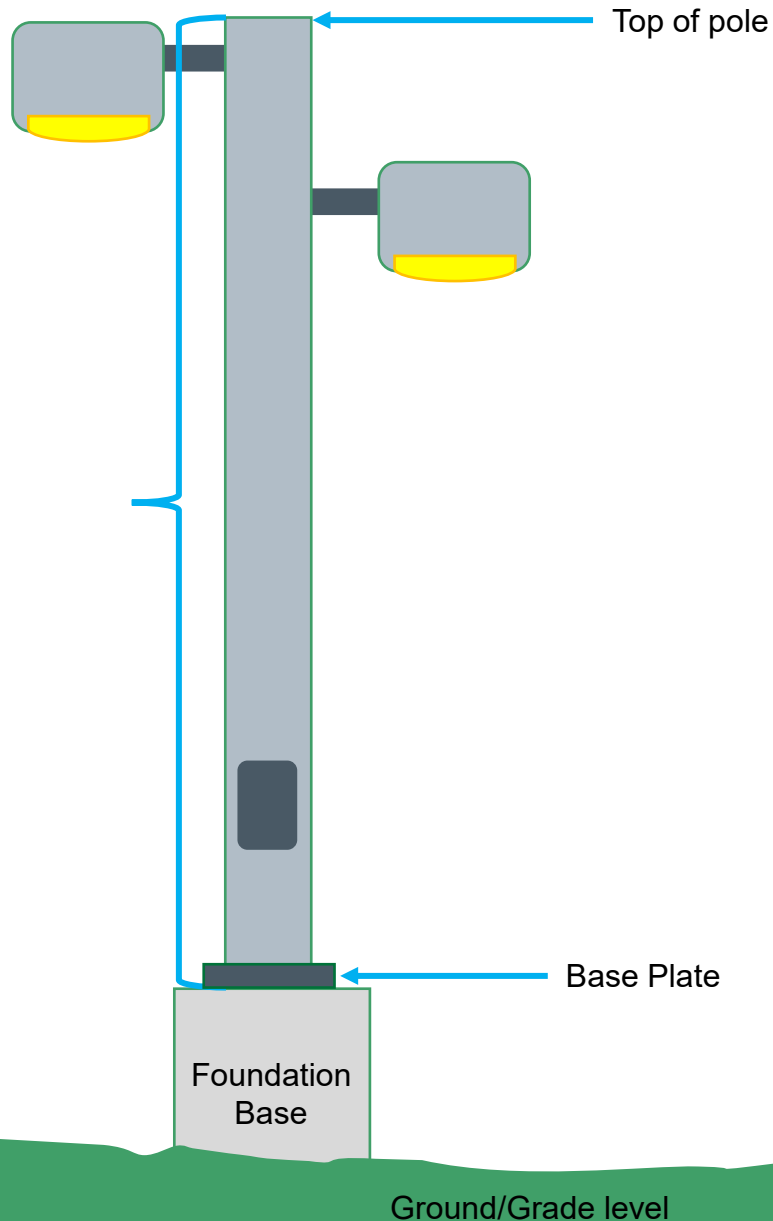

Pole Height is the dimension from the base plate of the pole to the top of the pole, the foundation height is not included.

It is determined by the desired mounting height of the luminaire. The lighting layout, luminaire optics and application (parking lot vs. highway) are all taken into consideration to determine pole height.

- As the pole gets taller, the pole's maximum weight and EPA will be reduced.

NOTE* If the pole is mounted on something taller like a parking garage, the extra height **MUST** be taken into consideration. "Technical Information" charts on Lithonia Lighting Pole spec sheets only account for 3ft foundations.

4

How to Size a Pole

SIZING A POLE TO PASS WIND LOADING

The process of sizing a pole combines *all* of the mounted item's dynamic loads (EPA), static loads (weight), the anticipated maximum wind speed based on design criteria's wind map and the pole height, to determine the mounting requirements for a particular application.

Mounted items include, but are not limited to:

- Luminaires
- Cameras
- Signs
- Brackets
- Banners
- Speakers
- Cables and catenary systems
- Electrical boxes
- Wireless access points
- Netting



STANDARD WIND LOADING PROCESS

Use the “Technical Information” charts on the desired pole series to determine which pole size will be able to hold all the weight and EPA of the mounted items @ the wind speed designated for the jobsite’s location, based on the assigned building code.

Most poles have 2 “Technical Information” charts.

1. AASHTO 1994
2. AASHTO 2013

The total EPA and weight of the mounted items **MUST NOT** exceed the maximums listed.

If either the total weight **OR** EPA exceeds, then the pole shaft diameter or wall thickness must be increased to one that is suitable for both.

TECHNICAL INFORMATION — EPA (ft²) with 1.3 gust											
Catalog Number	Nominal Shaft Length (ft.)*	Pole Shaft Size (Base in. x Top in. x ft.)	Wall thick (in)	Gauge	EPA (ft²) with 1.3 gust						Approximate ship weight (lbs.)
					80 MPH	Max. weight	90 MPH	Max. weight	100 MPH	Max. weight	
SSS 10 4C	10	4.0 x 10.0	0.120"	11	30.6	765	23.8	595	18.9	473	75
SSS 12 4C	12	4.0 x 12.0	0.120"	11	24.4	610	18.8	470	14.8	370	90
SSS 14 4C	14	4.0 x 14.0	0.120"	11	19.9	498	15.1	378	11.7	293	100
SSS 16 4C	16	4.0 x 16.0	0.120"	11	15.9	398	11.8	295	8.9	223	115
SSS 18 4C	18	4.0 x 18.0	0.120"	11	12.6	315	9.2	230	6.7	168	125
SSS 20 4C	20	4.0 x 20.0	0.120"	11	9.6	240	6.7	167	4.5	150	140
SSS 20 4G	20	4.0 x 20.0	0.179"	7	14	350	11	275	8	200	198
SSS 20 5C	20	5.0 x 20.0	0.120"	11	17.7	443	12.7	343	9.4	235	185
SSS 20 5G	20	5.0 x 20.0	0.179"	7	28.1	703	21.4	535	16.2	405	265
SSS 25 4C	25	4.0 x 25.0	0.120"	11	4.8	150	2.6	100	1	50	170
SSS 25 4G	25	4.0 x 25.0	0.179"	7	10.8	270	7.7	188	5.4	135	245
SSS 25 5C	25	5.0 x 25.0	0.120"	11	9.8	245	6.3	157	3.7	150	225
SSS 25 5G	25	5.0 x 25.0	0.179"	7	18.5	463	13.3	333	9.5	238	360
SSS 30 4G	30	4.0 x 30.0	0.179"	7	6.7	168	4.4	110	2.6	65	295
SSS 30 5C	30	5.0 x 30.0	0.120"	11	4.7	150	2	50	--	--	265
SSS 30 5G	30	5.0 x 30.0	0.179"	7	10.7	267	6.7	167	3.9	100	380
SSS 30 6G	30	6.0 x 30.0	0.179"	7	19	475	13.2	330	9	225	520
SSS 35 5G	35	5.0 x 35.0	0.179"	7	5.9	150	2.5	100	--	--	440
SSS 35 6G	35	6.0 x 35.0	0.179"	7	12.4	310	7.6	190	4.2	105	540
SSS 39 6G	39	6.0 x 39.0	0.179"	7	7.2	180	3	75	--	--	605

NOTE: EPA values are based ASCE 7-93 wind map.
* For 1/2 ft increments, add -6 to the pole height. Ex: 20-6 equals 20ft 6in.



EXAMPLE: SIZING A POLE TO PASS WIND LOADING

Ex. 1 Customer wants to install a square straight steel, 20ft pole in Houston, TX and will be drill mounting a quantity of 2, DSX2's on to the pole. The required building design criteria has been determined to be AAHSTO 2013.

Step 1: Identify the wind speed in Houston, TX under AASHTO 2013 Design Criteria using wind map ASCE 7-05.

It is **110 mph**.

Step 2: Calculate total EPAft² and Weight of all mounted items on the pole.

DSX2 EPA = 1.1ft² x Qty2 = **2.2 ft²**

DSX2 Weight = 36lbs x Qty2 = **72lbs**

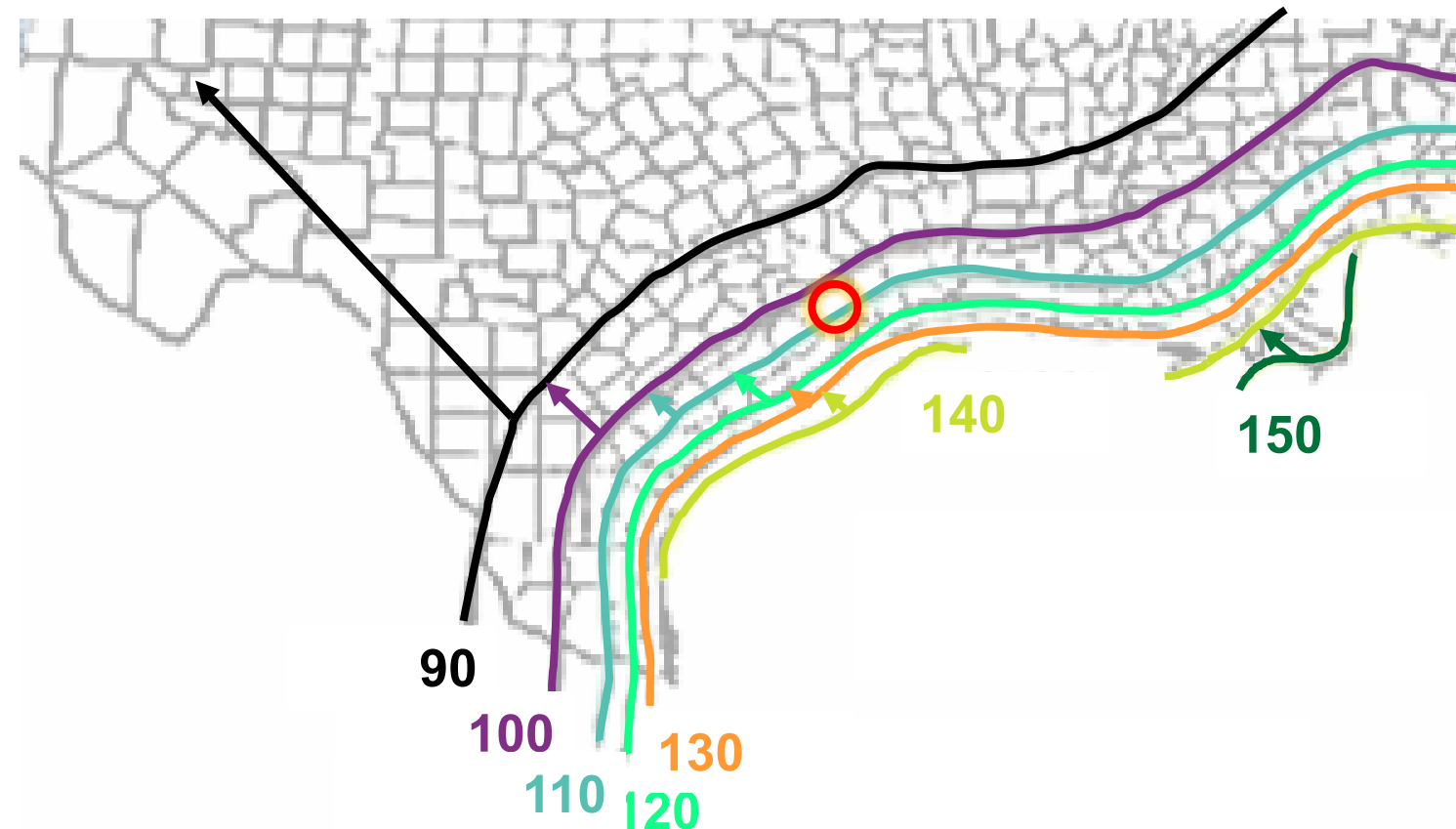

EXAMPLE: SIZING A POLE TO PASS WIND LOADING

Step 3: Identify the correct “Technical Information” chart on the series specsheet. Then the wind speed followed by the height. There are 4 sizes available – 4C, 4G, 5C and 5G. Now locate the size that meets or exceeds in both weight an EPA.
 DSX2 EPA = 1.1ft² x Qty2 = **2.2 ft²** DSX2 Weight = 36lbs x Qty2 = **72lbs**

TECHNICAL INFORMATION — EPA (ft ²) WITH 3-SECOND GUST PER AASHTO 2013																	
Series	Mounting Height (ft)*	Shaft Base Size	90 MPH	Max. weight	100 MPH	Max. weight	110 MPH	Max. weight	120 MPH	Max. weight	130 MPH	Max. weight	140 MPH	Max. weight	150 MPH	Max. weight	Approximate ship weight (lbs.)
SSS	10	4C	20	500	16	400	13	325	10.5	263	8.5	213	7	175	6	150	75
SSS	12	4C	16	400	13	325	10	250	8	200	6.5	163	5	125	4	100	90
SSS	14	4C	13.5	338	10	250	7.5	188	6	150	4.5	113	3.5	88	2.5	63	100
SSS	16	4C	10.5	263	7.5	188	5.5	138	4	100	3	75	1.5	38	1	25	115
SSS	18	4C	8	200	5.5	138	4	100	2.5	63	1.5	38	0.5	13	-	-	125
SSS	18	4G	13	325	9.5	238	7	175	5	125	3.5	88	2.5	63	1.5	38	185
SSS	18	5C	13	325	9.5	238	6.5	163	4.5	113	3	75	1.5	38	.5	13	170
SSS	20	4C	6	150	4	100	2.5	63	1	25	-	-	-	-	-	-	140
SSS	20	4G	10.5	263	7.5	188	5.5	138	3.5	88	2	50	1	25			205
SSS	20	5C	10	250	7	175	4.5	113	2.5	63	1	25	-	-	-	-	185
SSS	20	5G	20	500	15	375	11.5	288	8.5	213	6	150	4.5	113	3	75	265
SSS	25	4C	2	50	0.5	13	-	-	-	-	-	-	-	-	-	-	170
SSS	25	4G	5.5	138	3	75	1.5	38	-	-	-	-	-	-	-	-	245
SSS	25	5C	4.5	113	2	50	-	-	-	-	-	-	-	-	-	-	225
SSS	25	5G	12	300	8.5	213	5.5	138	3	75	1.5	38	-	-	-	-	360
SSS	25	6G	19	475	13.5	338	9	225	5.5	138	3	75	1	25			445

Solution: The 4C pole will not work because the weight maximum (**63lbs**) is less than quantity of 2 DSX2s. **SSS 20 4G** is the correct size because the Max. EPA (**5.5ft²**) and Max. weight (**138lbs**) both meet or exceed the quantity of 2 DSX2 fixtures.



CUSTOM WIND LOADING TO SIZE A POLE

Poles in areas of known abnormal conditions, known excessive loading conditions or needing a design criteria that we do not have “Technical Information” charts for, will require custom wind load calculations. Including but not limited to:

1. When the pole specification sheet does not have a “Technical Information” chart for the required design criteria like FBC (Florida Building code) and IBC (International Building code)
2. Poles located near or on airport property.
3. Poles located on top of parking decks, bridges or catwalks.
4. Poles located in expansive, flat locations with few things to block wind.
5. RFA modifications
 - a) Custom provisions/non-standard drillings (not including competitor drill patterns)
 - b) Poles with 3 or more provisions (custom or standard)
 - c) Banner arms and signs
 - d) Cables, Catenary lights and Eye bolts
 - e) Custom Anchorage and bases



CUSTOM WIND LOADING TO SIZE A POLE

If your pole falls into any of these categories, a request for wind load calculations with a completed “Wind Load & Anchorage Verification Form_092525” should be provided to ATS or Product Support Outdoor.

Once they verify all pertinent information is on the form, formal calculations will be completed.

- If the **pole passes**, the calculations will be provided.
- If the **pole does not pass**, alternate sizes will be provided.

It is VERY important to include ALL required information and to be as detailed as possible. Poles will be sized incorrectly and WILL FAIL if information, like the pole’s mounting height @ 28ft above grade, is missing.

Wind Loading, Anchorage Verification, and RFA Form

Note: If any information or documentation is not clear, we will return the request with “Needs Clarification”. Please be sure to attach all information for the request for this PDF.

Basic Information: *Required

Agency Name, Rep Name:	Agile Quote Number:
Requestor Email Address or Phone Number:	Bid Date:
Job Name:*	Job Location (City, State):*
Wind Zone Speed and Building Code/Design Criteria: * i.e. AASHTO year, IBC, etc.	Special Location: * i.e. Airport, parking deck, N/A etc.

Additional Submittal Documentation:

Check off documentation included in request and attach to this PDF.

- Reference Drawings
If yes, please attach to this PDF
- Anchorage Verification Form
(Required for modified base or to match existing anchorage, [form found below](#))
- Specification Sheets
If yes, please attach to this PDF
- Competitor drill pattern (SPDRILLxx)
If yes, please attach to this PDF
- Regulations; Compliance
If yes, please specify > _____
- Other
If yes, please specify > _____

Pole and Fixture Information: (All Required)

Pole Description: (i.e. SSS 20 4C DM19AS VD EHH4A DDBXD)	Pole Base Mounting Height: i.e. at grade, foundation-parking garage-bridge height, transformer base, etc.
Fixture Weight and EPA (per fixture):	Fixture Mounting Details (if not standard): i.e. competitor drill pattern (SPDRILLxx), lower drill height, or orientation change.



EXAMPLE: CUSTOM WIND LOADING

Ex. 2 Customer wants to install a 35ft pole in Green Bay, WI but they do not know what pole series they should use or the size. They will be mounting a quantity of 2, RSX3's on to a bullhorn (BS28). The required design criteria has been determined to be IBC 2012.

Step 1: Identify the wind speed in Green Bay, WI under IBC 2012 Design Criteria (uses wind map ASCE 7-10).

It is **115 mph**

Step 2: Calculate total EPAft² and Weight of all mounted items on the pole (found on series spec sheets).

RSX3 EPA = $0.7\text{ft}^2 \times \text{Qty}2 = 1.4\text{ft}^2$ + BS28 EPA = 0.1ft^2

Total EPA = **1.5ft²**

RSX3 Weight = $48\text{lbs.} \times \text{Qty}2 = 144\text{lbs.}$ + BS28 Weight = **20lbs.**

Total Weight = **164lbs.**

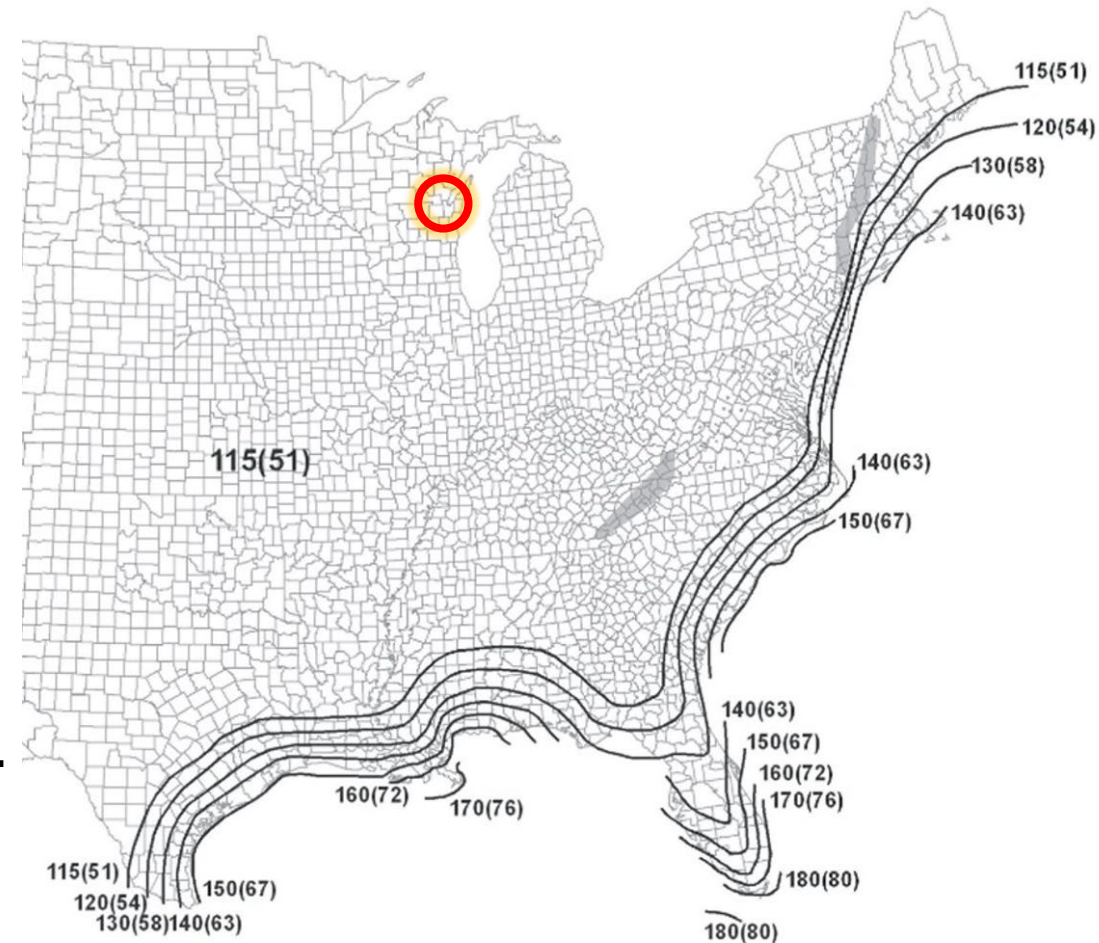

EXAMPLE: CUSTOM WIND LOADING



Step 3: Help select a pole based on location.

- A Round Tapered pole will be best for heights 30'+.
- An Aluminum pole will be best for the more corrosive, great lake/heavy snow environment.

Step 4: Identify the EPA and Weight maximums for RTA 35' pole with 115MPH/ IBC 2012 criteria by submitting a completed "Wind Load & Anchorage Verification Form_ 092525" to the Product Support Outdoor email.

Solution: The pole size will be determined by engineering after calculations are completed. The size and wind load calculations report will be sent back via email.

EXAMPLE: CUSTOM WIND LOADING

Step 3: Help select a pole based on location.

- A Round Tapered pole will be best for heights 30'+.
- An Aluminum pole will be best for the more corrosive, great lake/heavy snow environment.

Step 4: Identify the correct “Technical Information” chart on the series specsheet (ASSUME AASHTO 2013). Then the wind speed followed by the height (90mph). There are 6 sizes available – 8E, 8G, 9G, 8J, 10G and 10J. Now locate the size that meets or exceeds in both weight an EPA.

RSX3 + BS28 EPA = **1.5 ft²**

RSX3 + BS28 Weight = **164lbs.**

Solution: RTA 35 10G is the correct size because the Max. EPA (**18.7ft²**) and Max. weight (**200lbs**) both meet or exceed the quantity of 2 RSX3 fixtures. The other 35' poles will not be able to hold the weight.

TECHNICAL INFORMATION (cont.)— EPA (ft ²) WITH 3-SECOND GUST PER AASHTO 2013																
Series	Mounting Height (ft)*	Shaft Base Size	90 MPH	Max. weight	100 MPH	Max. weight	110 MPH	Max. weight	120 MPH	Max. weight	130 MPH	Max. weight	140 MPH	Max. weight	150 MPH	Max. weight
RTA	30	8J	18.9	150	14.6	150	11.7	150	9.6	150	8	150	6.7	150	5.6	150
RTA	30	10G	24.6	200	19.6	200	15.8	200	13	200	10.7	200	8.8	200	7.3	200
RTA	30	10J	33.7	300	26.9	300	21.9	300	18.1	300	15	300	12.6	300	10.6	300
RTA	33	8E	7.8	150	5.7	150	4.3	150	3.4	150	2.6	150	2	150	1.5	150
RTA	33	8G	10.6	150	7.9	150	6.2	150	4.9	150	3.9	150	3.1	150	2.5	150
RTA	33	9G	15.5	150	11.9	150	9.5	150	7.6	150	6.2	150	5.1	150	4.1	150
RTA	33	8J	15.7	150	12.1	150	9.6	150	7.8	150	6.4	150	5.3	150	4.4	150
RTA	33	10G	20.8	200	16.5	200	13.2	200	10.7	200	8.8	200	7.2	200	5.8	200
RTA	33	10J	28.9	300	23	300	18.6	300	15.3	300	12.6	300	10.5	300	8.7	300
RTA	35	8E	6.3	150	4.4	150	3.2	150	2.4	150	1.8	150	1.3	150	0.9	150
RTA	35	8G	8.9	150	6.5	150	5	150	3.9	150	3	150	2.4	150	1.8	150
RTA	35	9G	13.6	150	10.4	150	8.2	150	6.6	150	5.3	150	4.2	150	3.4	150
RTA	35	8J	13.9	150	10.6	150	8.4	150	6.7	150	5.5	150	4.4	150	3.6	150
RTA	35	10G	18.7	200	14.7	200	11.7	200	9.4	200	7.6	200	6.1	200	4.9	200
RTA	35	10J	25.9	300	20.6	300	16.6	300	13.6	300	11.2	300	9.3	300	7.7	300

HELPFUL RESOURCES

[WEB LINK](#): Wind Load and Anchorage Verification Form

[WEB LINK](#): RFA Reference Guide (2 pager)

[WEB LINK](#): PE Stamp Process and FAQ

[WEB LINK](#): Detailed Information on Pole Vibration

[WEB LINK](#): How to Size a Pole Training deck

Wind Maps and Wind Speeds

Design criteria

Process to size poles



PolesCentral - [LINK](#)

- A resource page for all things poles
- Can be searched on Acuity Brands.com
- Link can be found on all pole series web pages

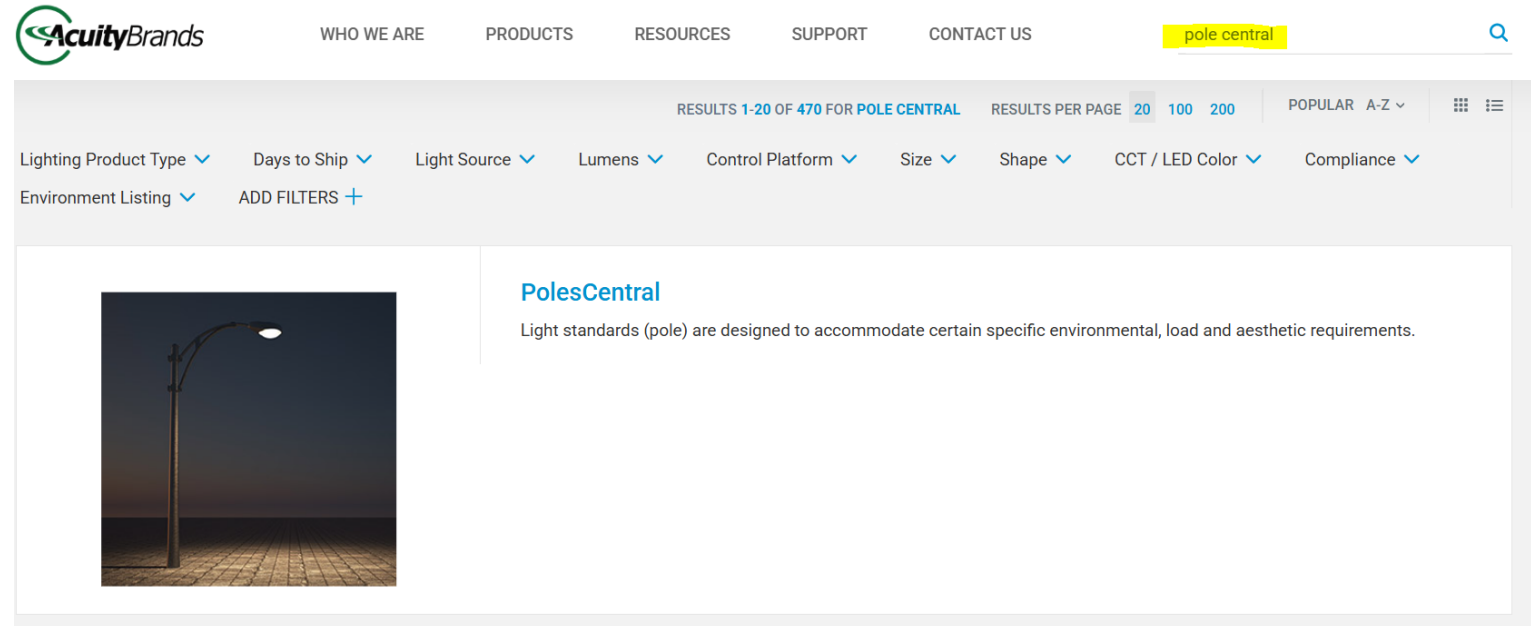

The screenshot shows the Acuity Brands website search results for 'pole central'. The search bar at the top right contains the text 'pole central'. Below the search bar, the navigation menu includes 'WHO WE ARE', 'PRODUCTS', 'RESOURCES', 'SUPPORT', and 'CONTACT US'. The search results section displays 'RESULTS 1-20 OF 470 FOR POLE CENTRAL' and 'RESULTS PER PAGE 20 100 200'. A filter bar includes 'Lighting Product Type', 'Days to Ship', 'Light Source', 'Lumens', 'Control Platform', 'Size', 'Shape', 'CCT / LED Color', and 'Compliance'. A main image shows a street light pole, and the text below it reads 'PolesCentral' and 'Light standards (pole) are designed to accommodate certain specific environmental, load and aesthetic requirements.'

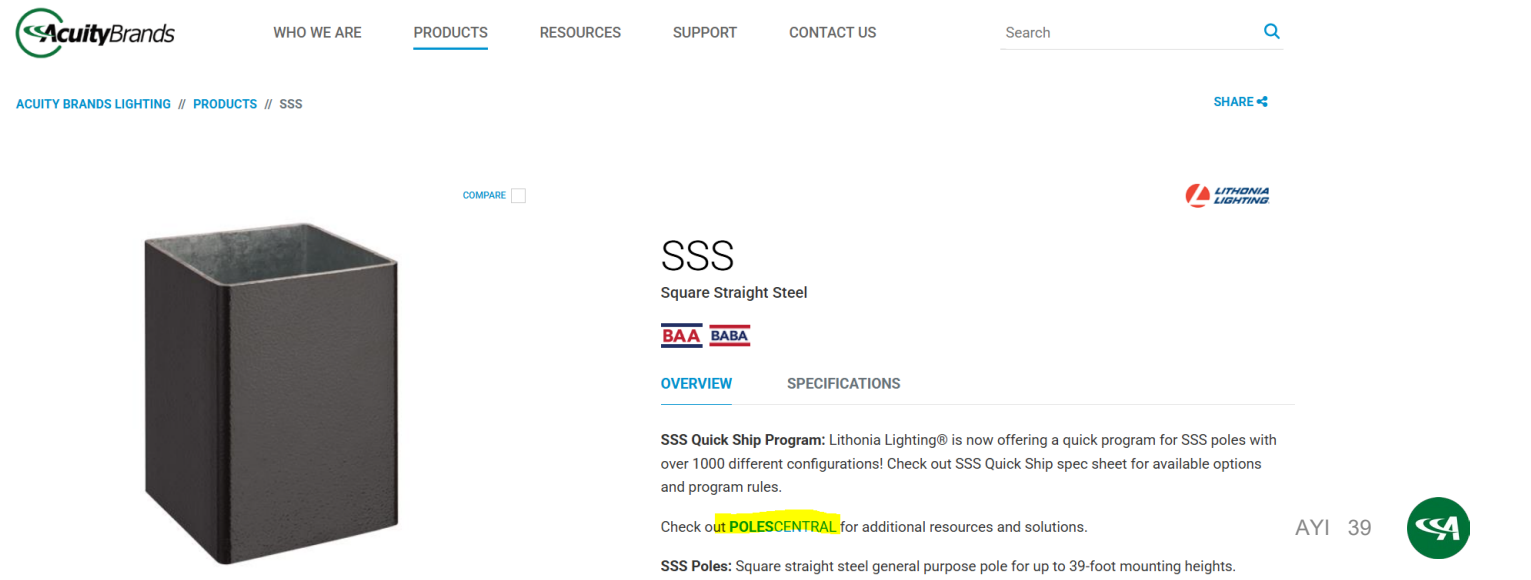

The screenshot shows the Acuity Brands website product page for 'SSS Square Straight Steel'. The navigation menu includes 'WHO WE ARE', 'PRODUCTS', 'RESOURCES', 'SUPPORT', and 'CONTACT US'. The breadcrumb trail reads 'ACUITY BRANDS LIGHTING // PRODUCTS // SSS'. The product image shows a dark, square, straight steel pole. The product name 'SSS' is displayed in large text, followed by 'Square Straight Steel'. The 'LITHONIA LIGHTING' logo is visible in the top right corner. The 'OVERVIEW' and 'SPECIFICATIONS' tabs are visible. The text below the tabs reads: 'SSS Quick Ship Program: Lithonia Lighting® is now offering a quick program for SSS poles with over 1000 different configurations! Check out SSS Quick Ship spec sheet for available options and program rules.' Below this, it says 'Check out [POLESCENTRAL](#) for additional resources and solutions.' The page number 'AYI 39' is visible in the bottom right corner, along with the Acuity Brands logo.



Thank You

Elaine Boone

Pole Product Manager

Elaine.boone@acuitybrands.com